

Holder for lateral guide, flexible

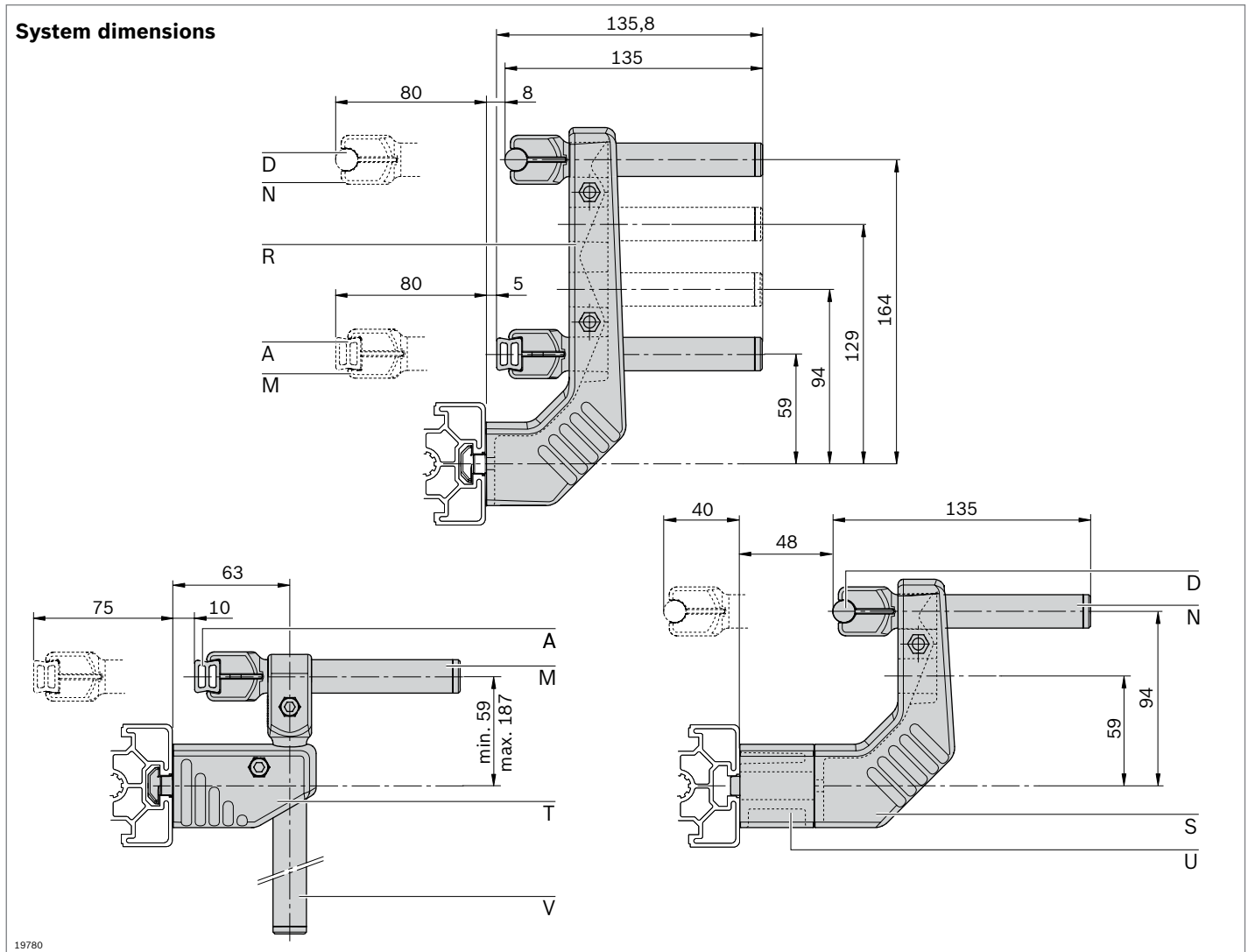

- ▶ Holders and clamping holders make variable adjustment of the guide height and width possible
- ▶ Easy to clean

Note: For stability in the direction of rotation, at least 2 holders must be connected with a continuous profile rail.



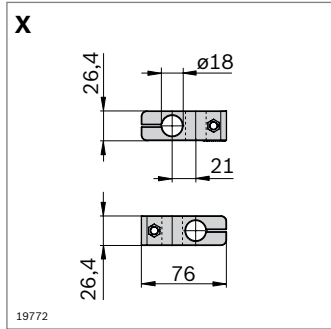

- ▶ Crosspiece for intersecting, perpendicular connections of tubes D18 (**W**) and clamping holders C L100 (**M**) or D12 L100 (**N**)
- ▶ Optional accessories: Clamping lever M6x40 (p. 4-11)

| Crosspiece |  | No. |
|------------|---|----------------------|
| | 10 | 3 842 539 501 |
| Material: | Cross piece: PA; black Nut, screw: Steel; stainless | |

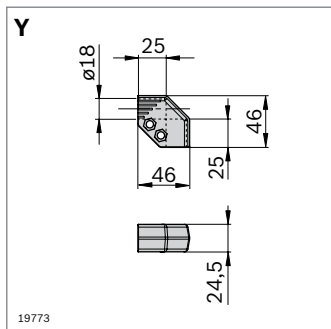

- ▶ Corner piece for end-to-end, perpendicular connections of tubes D18 (**W**) and clamping holders C L100 (**M**) or D12 L100 (**N**)

| Corner piece |  | No. |
|--------------|---|----------------------|
| | 10 | 3 842 539 505 |
| Material: | Corner piece: PA; black Nut, screw: Steel; stainless | |

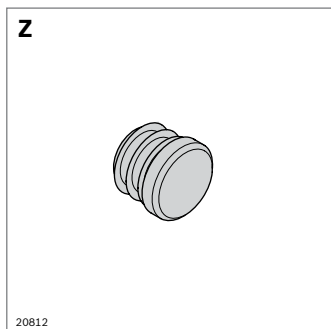

- ▶ Plug for sealing clamping holder C L100, (**M**), clamping holder D12 L100 (**N**), vertical clamping holder D18 L160 (**V**) or tube D18 (**W**)

| Plug |  | No. |
|-----------|---|----------------------|
| | 10 | 3 842 539 826 |
| Material: | PA; black | |

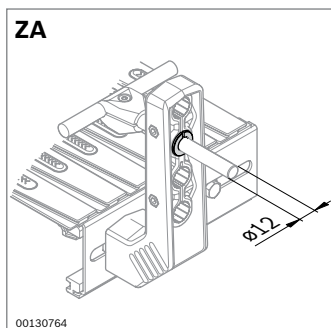

- ▶ Reducing adapter for accommodating round profiles ø 12 in D18 mountings

| Reduction piece |  | No. |
|-----------------|---|----------------------|
| | 20 | 3 842 539 344 |
| Material: | PA; black | |