

Specification Status: Released



GENERAL DESCRIPTION

TE PolyZen devices are polymer enhanced, precision Zener diode micro-assemblies. They offer resettable protection against multi-Watt fault events without the need for multi-Watt heat sinks.

The Zener diode used for voltage clamping in a PolyZen micro-assembly was selected due to its relatively flat voltage vs current

response. This helps improve output voltage clamping, even when input voltage is high and diode currents are large.

An advanced feature of the PolyZen micro-assembly is that the Zener diode is thermally coupled to a resistively non-linear, polymer PTC (positive temperature coefficient) layer. This PTC layer is fully integrated into the device, and is electrically in series between V_{IN} and the diode clamped V_{OUT} .

This advanced PTC layer responds to either extended diode heating or overcurrent events by transitioning from a low to high resistance state, also known as "tripping". A tripped PTC will limit current and generate voltage drop. It helps to protect both the Zener diode and the follow on electronics and effectively increases the diode's power handling capability.

The polymer enhanced Zener diode helps protect sensitive portable electronics from damage caused by inductive voltage spikes, voltage transients, incorrect power supplies and reverse bias. These devices are particularly suitable for portable electronics and other low-power DC devices.

BENEFITS

- Stable Zener diode helps shield downstream electronics from overvoltage and reverse bias
- Trip events shut out overvoltage and reverse bias sources
- Analog nature of trip events minimizes upstream inductive spikes
- Minimal power dissipation requirements
- Single component placement

FEATURES

- Overvoltage transient suppression
- Stable V_Z vs fault current
- Time delayed, overvoltage trip
- Time delayed, reverse bias trip
- Multi-Watt power handling capability
- Integrated device construction
- RoHS Compliant

TARGET APPLICATIONS

- DC power port protection in portable electronics
- DC power port protection for systems using barrel jacks for power input
- Internal overvoltage & transient suppression
- DC output voltage regulation

TYPICAL APPLICATION BLOCK DIAGRAM

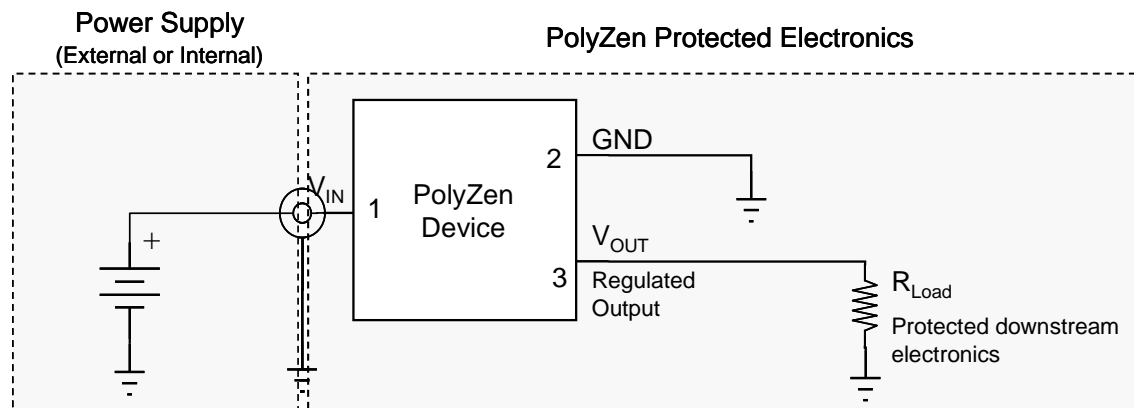

CONFIGURATION INFORMATION

Pin Configuration (Top View)

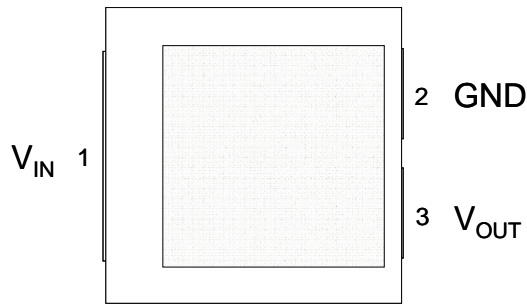

Pad Dimensions

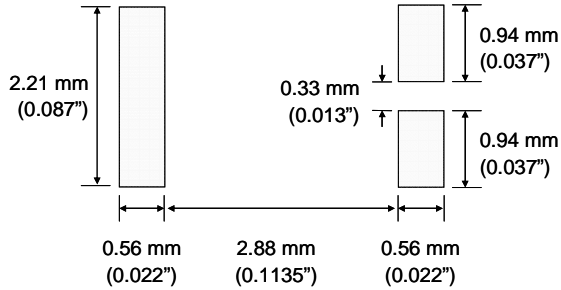

PIN DESCRIPTION

Pin Number	Pin Name	Pin Function
1	V _{IN}	V _{IN} - Protected input to Zener diode.
2	GND	GND
3	V _{OUT}	V _{OUT} - Zener regulated voltage output

BLOCK DIAGRAM

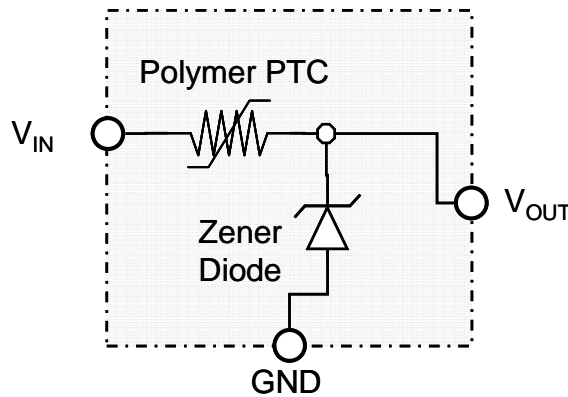

DEFINITION of TERMS

I _{PTC}	Current flowing through the PTC portion of the circuit
I _{FLT}	RMS fault current flowing through the diode
I _{OUT}	Current flowing out the V _{OUT} pin of the device
Trip Event	A condition where the PTC transitions to a high resistance state, thereby significantly limiting I _{PTC} and related currents.
Trip Endurance	Time the PTC portion of the device remains in a high resistance state.

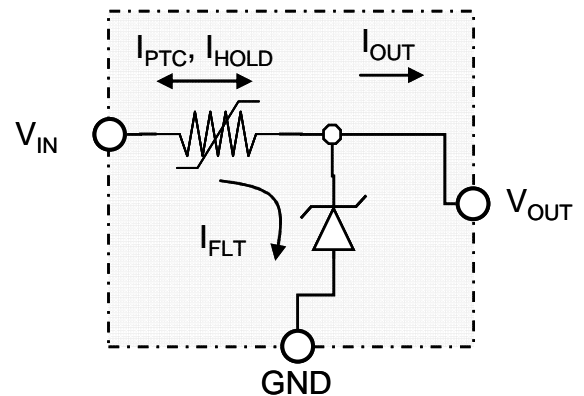

PolyZen

Polymer Enhanced Zener Diode Micro-Assemblies

PRODUCT: ZEN132V230A16LS

DOCUMENT: SCD27362
REV LETTER: D
REV DATE: MAY 11, 2011
PAGE NO.: 3 OF 8

GENERAL SPECIFICATIONS

Operating Temperature -40° to +85°C
Storage Temperature -40° to +85°C

ELECTRICAL CHARACTERISTICS^{1-3, 11} (Typical unless otherwise specified)

V _Z ⁴ (V)			I _{Zt} ⁴ (A)	I _{HOLD} ⁵ @20°C (A)	Leakage Current		R Typ ⁶ (Ohms)	R _{1Max} ⁷ (Ohms)	V _{INT} Max ⁸ (V)		I _{FLT} Max ⁹		Tripped Power Dissipation ¹⁰ Max	
									V _{INT} Max (V)	Test Current (A)	I _{FLT} Max (A)	Test Voltage (V)	Value (W)	Test Voltage (V)
Min	Typ	Max			Test Voltage	Max Current (mA)								
13.2	13.4	13.6	0.1	2.3	13.15	5	0.04	0.06	16V	5A	+2 -40	+20 -12V	0.8	20

- Note 1: Electrical characteristics determined at 25°C unless otherwise specified.
- Note 2: This device is intended for limited fault protection. Repeated trip events or extended trip endurance can degrade the device and may affect performance to specifications. Performance impact will depend on multiple factors including, but not limited to, voltage, trip current, trip duration, trip cycles, and circuit design. For details or ratings specific to your application contact TE Connectivity Circuit Protection directly.
- Note 3: Specifications developed using 1.0 ounce 0.045" wide copper traces on dedicated FR4 test boards. Performance in your application may vary.
- Note 4: I_{Zt} is the current at which V_Z is measured (V_Z = V_{OUT}). Additional V_Z values are available on request.
- Note 5: I_{HOLD}: Maximum steady state I_{PTC} (current entering or exiting the V_{IN} pin of the device) that will not generate a trip event at the specified temperature. Specification assumes I_{FLT} (current flowing through the Zener diode) is sufficiently low so as to prevent the diode from acting as a heat source. Testing is conducted with an "open" Zener.
- Note 6: R Typ: Resistance between V_{IN} and V_{OUT} pins during normal operation at room temperature.
- Note 7: R_{1Max}: The maximum resistance between V_{IN} and V_{OUT} pins at room temperature, one hour after 1st trip or after reflow soldering.
- Note 8: V_{INT} Max: V_{INT} Max relates to the voltage across the PPTC portion of the PolyZen device (V_{IN}-V_{OUT}). V_{INT} Max is defined as the voltage (V_{IN}-V_{OUT}) at which typical qualification devices (98% devices, 95% confidence) survived at least 100 trip cycles and 24 hours trip endurance at the specified voltage (V_{IN}-V_{OUT}) and current (I_{PTC}). V_{INT} Max testing is conducted using a "shorted" load (V_{OUT} = 0 V). V_{INT} Max is a survivability rating, not a performance rating.
- Note 9: I_{FLT} Max: I_{FLT} Max relates to the steady state current flowing through the diode portion of the PolyZen device in a fault condition, prior to a trip event. I_{FLT} Max is defined as the current at which typical qualification devices (12 parts per lot from 3 lots) survived 100 test cycles. RMS fault currents above I_{FLT} Max may permanently damage the diode portion of the PolyZen device. Testing is conducted with NO load connected to V_{OUT}, such that I_{OUT} = 0. "Test voltage" is defined as the voltage between V_{IN} to GND and includes the PolyZen Diode drop. Specification is dependent on the direction of current flow through the diode. I_{FLT} Max is a survivability rating, not a performance rating.
- Note 10: The power dissipated by the device when in the "tripped" state, as measured on TE test boards (see note 3).
- Note 11: Specifications based on limited qualification data and subject to change.

MECHANICAL DIMENSIONS

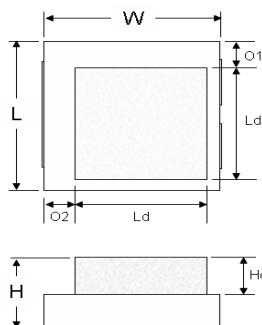

		Min	Typical	Max
Length	L	3.85 mm (0.152")	4 mm (0.16")	4.15 mm (0.163")
Width	W	3.85 mm (0.152")	4 mm (0.16")	4.15 mm (0.163")
Height	H	1.4mm (0.055")	1.7 mm (0.067")	2.0 mm (0.081")
Length Diode	Ld	-	3.0 mm (0.118")	-
Height Diode	Hd	-	1.0 mm (0.039")	-
Offset	O1	-	0.6 mm (0.024")	-
Offset	O2	-	0.7 mm (0.028")	-

SOLDER REFLOW RECOMMENDATIONS:

Classification Reflow Profiles	
Profile Feature	Pb-Free Assembly
Average Ramp-Up Rate (T _{smax} to T _p)	3° C/second max.
Preheat	
• Temperature Min (T _{smin})	150 °C
• Temperature Max (T _{smax})	200 °C
• Time (t _{smin} to t _{smax})	60-180 seconds
Time maintained above:	
• Temperature (T _L)	217 °C
• Time (t _L)	60-150 seconds
Peak/Classification Temperature (T_p)	260 °C
Time within 5 °C of actual Peak Temperature (t_p)	20-40 seconds
Ramp-Down Rate	6 °C/second max.
Time 25 °C to Peak Temperature	8 minutes max.

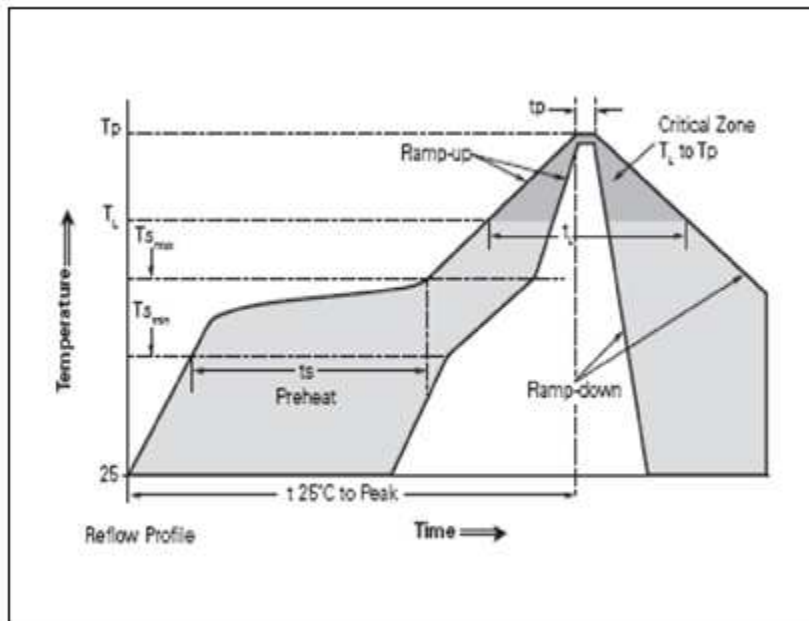

PolyZen
Polymer Enhanced Zener Diode
Micro-Assemblies

PRODUCT: ZEN132V230A16LS

DOCUMENT: SCD27362
REV LETTER: D
REV DATE: MAY 11, 2011
PAGE NO.: 5 OF 8

PACKAGING

Packaging	Tape & Reel	Standard Box
ZENXXXVXXXAXLS	3,000	15,000

Reel Dimensions for PolyZen Devices

$A_{max} = 330$
 $N_{min} = 102$
 $W_1 = 8.4$
 $W_2 = 11.1$

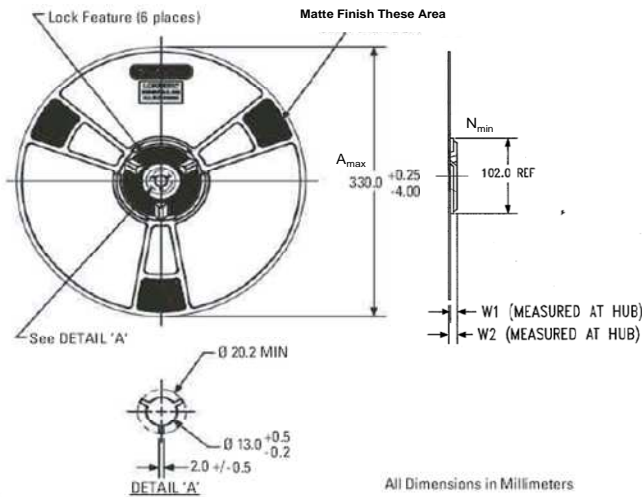

Taped Component Dimensions for PolyZen Devices

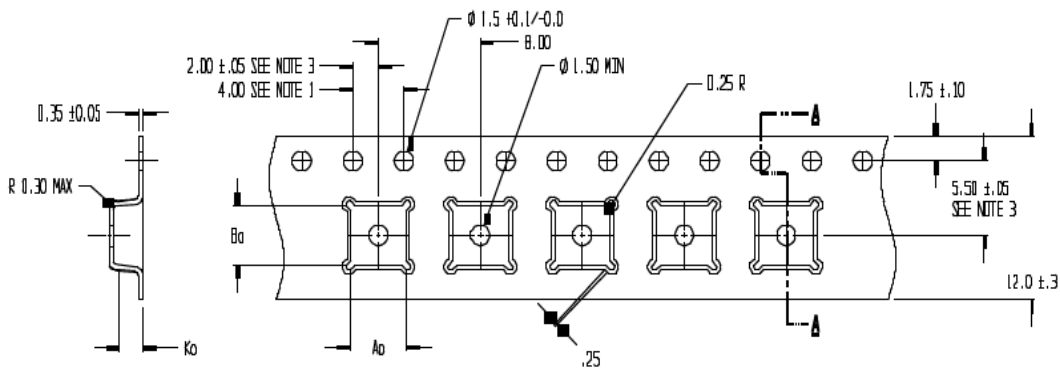

NOTES:

- $A_a = 4.35$
- $B_a = 4.35$
- $K_o = 2.30$
- 1. 10 SPROCKET HOLE PITCH CUMULATIVE TOLERANCE ± 0.2
- 2. CAMBER IN COMPLIANCE WITH EIA 481
- 3. POCKET POSITION RELATIVE TO SPROCKET HOLE MEASURED AS TRUE POSITION OF POCKET, NOT POCKET HOLE

PolyZen
Polymer Enhanced Zener Diode
Micro-Assemblies

Typical Fault Response: ZEN132V230A16LS
20 V/2 A Current Limited Source ($I_{OUT}=0$)

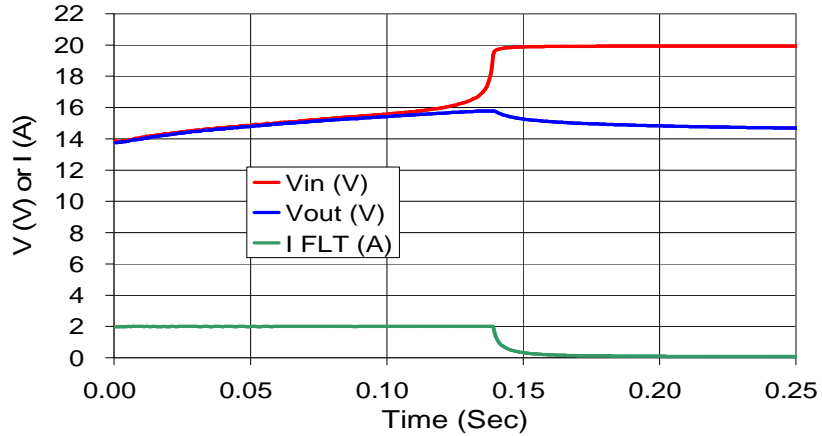

Pulse IV (300µsec Pulse)

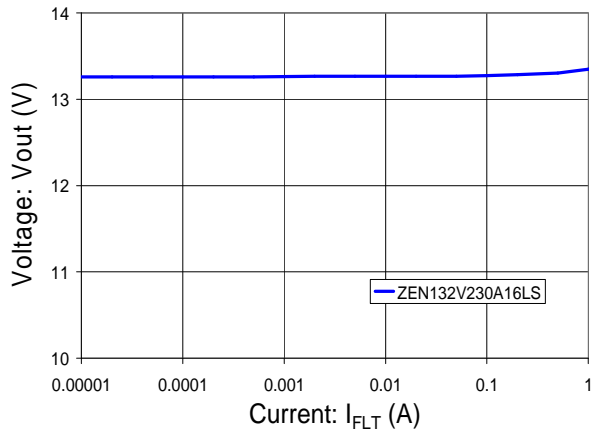

Pulse IV (300µsec Pulse)

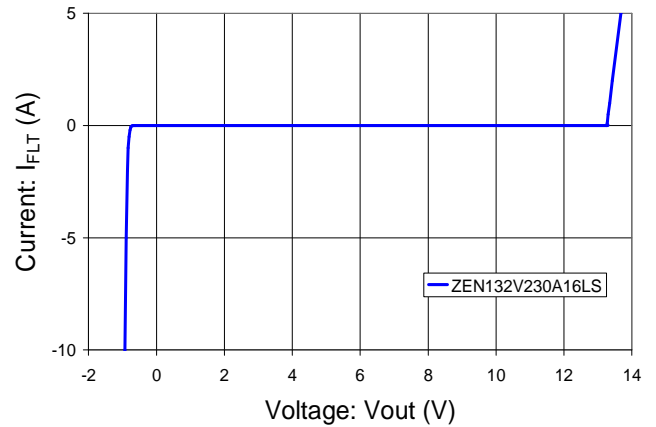

V_{OUT} Peak vs. I_{FLT} RMS ($I_{OUT}=0$)

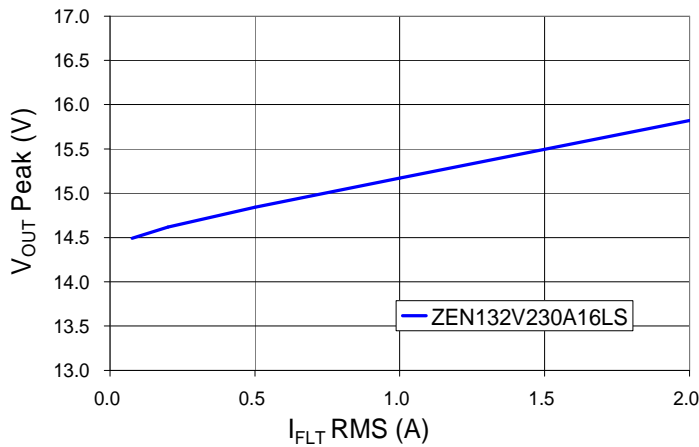

Time to Trip vs. I_{FLT} ($I_{OUT}=0$)

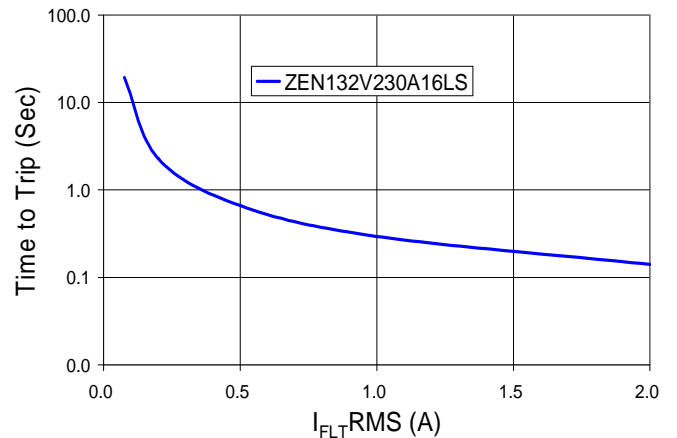

PolyZen
Polymer Enhanced Zener Diode
Micro-Assemblies

PRODUCT: ZEN132V230A16LS

DOCUMENT: SCD27362
REV LETTER: D
REV DATE: MAY 11, 2011
PAGE NO.: 7 OF 8

V_{OUT} Peak vs. I_{FLT} (I_{OUT}=0)

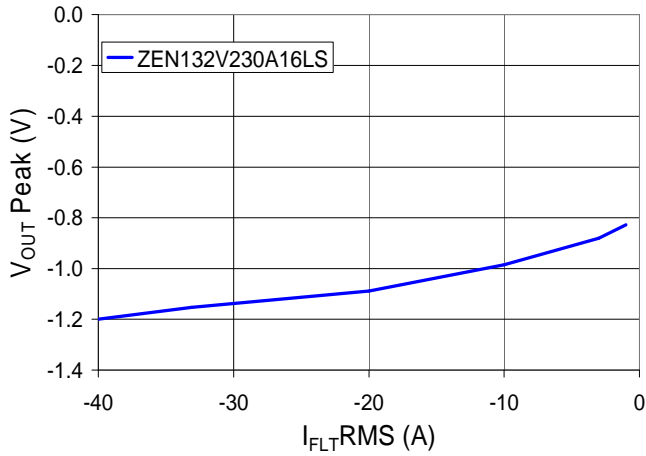

Time To Trip vs. I_{FLT} (I_{OUT}=0)

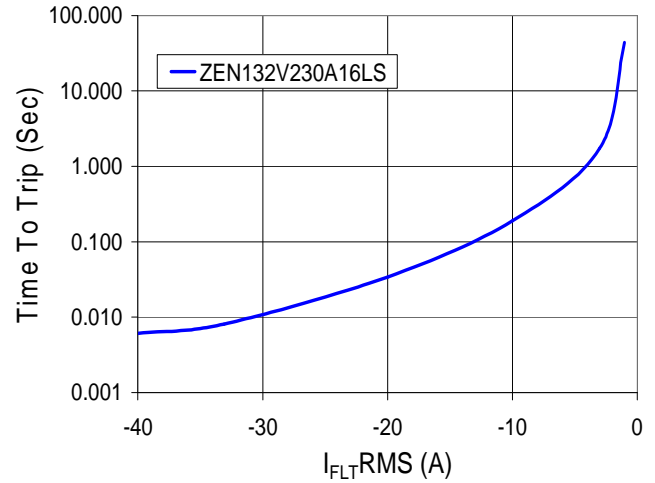

Temperature Effect on I_{Hold} (I_{FLT} = 0)

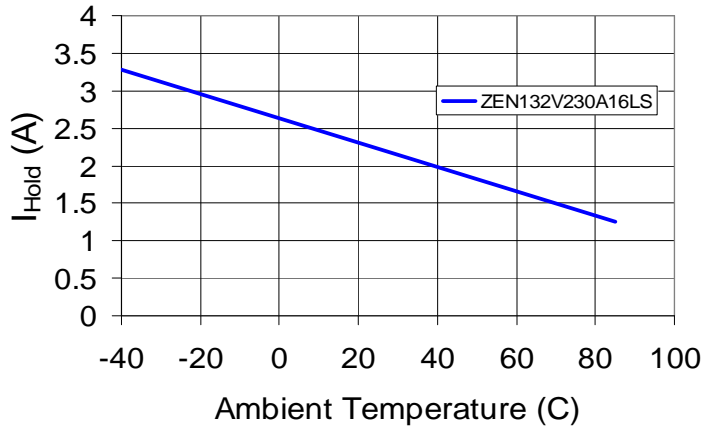

Time to Trip vs. I_{PTC} RMS (I_{FLT}=0)

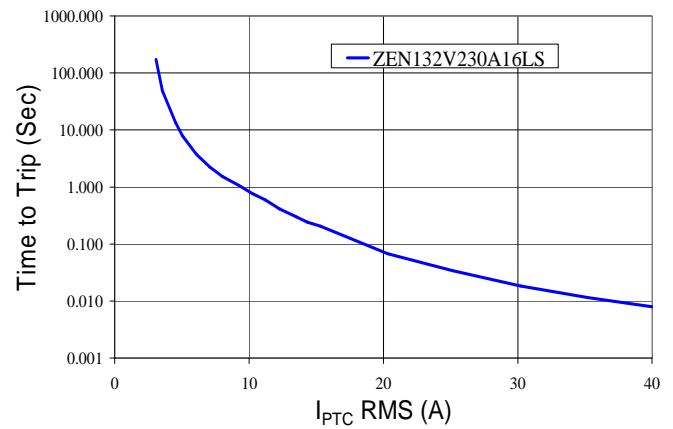

Temperature Effect on R_{TYP}

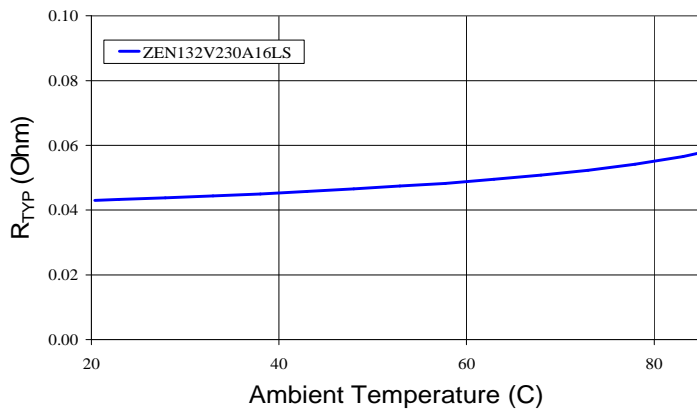

PolyZen

Polymer Enhanced Zener Diode Micro-Assemblies

PRODUCT: ZEN132V230A16LS

DOCUMENT: SCD27362
REV LETTER: D
REV DATE: MAY 11, 2011
PAGE NO.: 8 OF 8

Materials Information

ROHS Compliant

Directive 2002/95/EC
Compliant

ELV Compliant

Directive 2000/53/EC
Compliant

Pb-Free



Information furnished is believed to be accurate and reliable. However, users should independently evaluate the suitability of each product for their applications. Tyco Electronics Corporation and its affiliates in the TE Connectivity Ltd. group of companies ("TE") reserves the right to change or update, without notice, any information contained in this publication; to change, without notice, the design, construction, processing, or specification of any product; and to discontinue or limit production or distribution of any product. TE assumes no responsibility for the use of its product or for any infringement of patents or other rights of third parties resulting from the use of its product. No license is granted by implication or otherwise under any patent or proprietary right of TE except the right to use such product for the purpose for which it is sold. This publication supersedes and replaces all information previously supplied. Without expressed or written consent by an officer of TE, TE does not authorize the use of any of its products as components in nuclear facility applications, aerospace, or in critical life support devices or systems. TE's only obligations are those in the TE Standard Terms and Conditions of Sale and in no case will TE be liable for any incidental, indirect, or consequential damages arising from the sale, resale, use, or misuse of its products.