



UTILITY PUMPS

a xylem brand



40-size UTILITY PUMP with 1" ports and AC electric motor

PUMP MODELS

- 53041-2003-230** 230 volt 1 phase 50 Hz, 0.3kW (Continuous rated motor)
- 53041-2003-110** 110 volt 1 phase 50 Hz, 0.3Kw (Continuous rated motor)
- 53040-2003** 230 volt 1 phase 50 Hz, 0.25kW (40 minute rated motor)
- 53040-2103** 110 volt 1 phase 50 Hz, 0.25kW (40 minute rated motor)
- 53041-2003-400** 400 volt 3 phase 50 Hz, 0.37kW (No handle)

- ◆ Nitrile oil-resistant impeller fitted as standard.
- ◆ Neoprene impeller versions available.

Also available: reduced flow versions for liquid viscosity up to 700cp. Check with your pump supplier.

SPECIFICATION

Pump body: bronze **Weight:** 11kg
Shaft: AISI316 stainless steel
Shaft seal: mechanical (carbon-ceramic)
Impeller: see pump models above
 Max. recommended liquid viscosity: 150cp. Check with your pump supplier if in doubt.
Motor: 4 pole, totally enclosed, fan ventilated, IP55 enclosure. Single-phase motors fitted with manual reset thermal overload cut-out.

- ◆ Rapid self-priming up to 2 metres vertical lift.
- ◆ Handles hard and soft solids up to 4mm in size.
- ◆ Can pump up to 90% entrained air.
- ◆ Up to 30 minutes dry running protection.
- ◆ Quick and simple to maintain
- ◆ Light, compact, portable and tough

WARNING



Explosive hazard. Do not pump gasoline, solvents, thinners or other flammable liquids. To do so can cause an explosion resulting in injury or death

Performance figures are based on manufacturer's tests with water and are not guaranteed for any particular application

Product descriptions and specifications are subject to alteration without notice

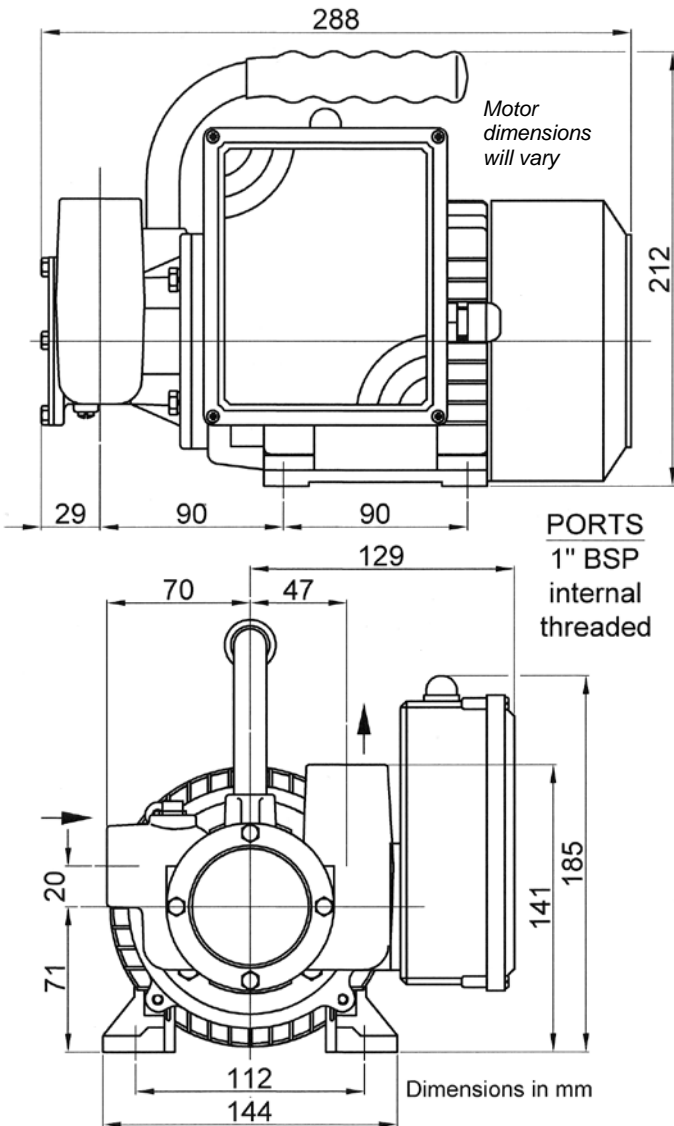

PUMP PERFORMANCE

