

THIS DRAWING IS UNPUBLISHED. RELEASED FOR PUBLICATION OCT. 2003.
 © COPYRIGHT 2003 By - ALL RIGHTS RESERVED.

NOTE
 1. MATERIAL : HOUSING : HIGH TEMPERATURE THERMO PLASTIC UL94V-0
 COLOR: BLACK
 CONTACT : COPPER ALLOY
 SOLDER PEG : COPPER ALLOY
 2. FINISH : CONTACT : GOLD FLASH ON CONTACT AREA, ALL OVER NICKEL.
 SOLDER PEG : TIN PLATE, ALL OVER NICKEL
 3. TOLERANCES NON-CUMMURATIVE
 4. -D- IS THE TOP SURFACE OF PCB.
 5. COMPONENT KEEP OUT AREA BASED ON MINI PCI EXPRESS SPECIFICATION
 1.0 CANDIDATE DRAFT (v1)
 6. THE FLOATING VALUE BY SOLDERING IS NOT INCLUDED.

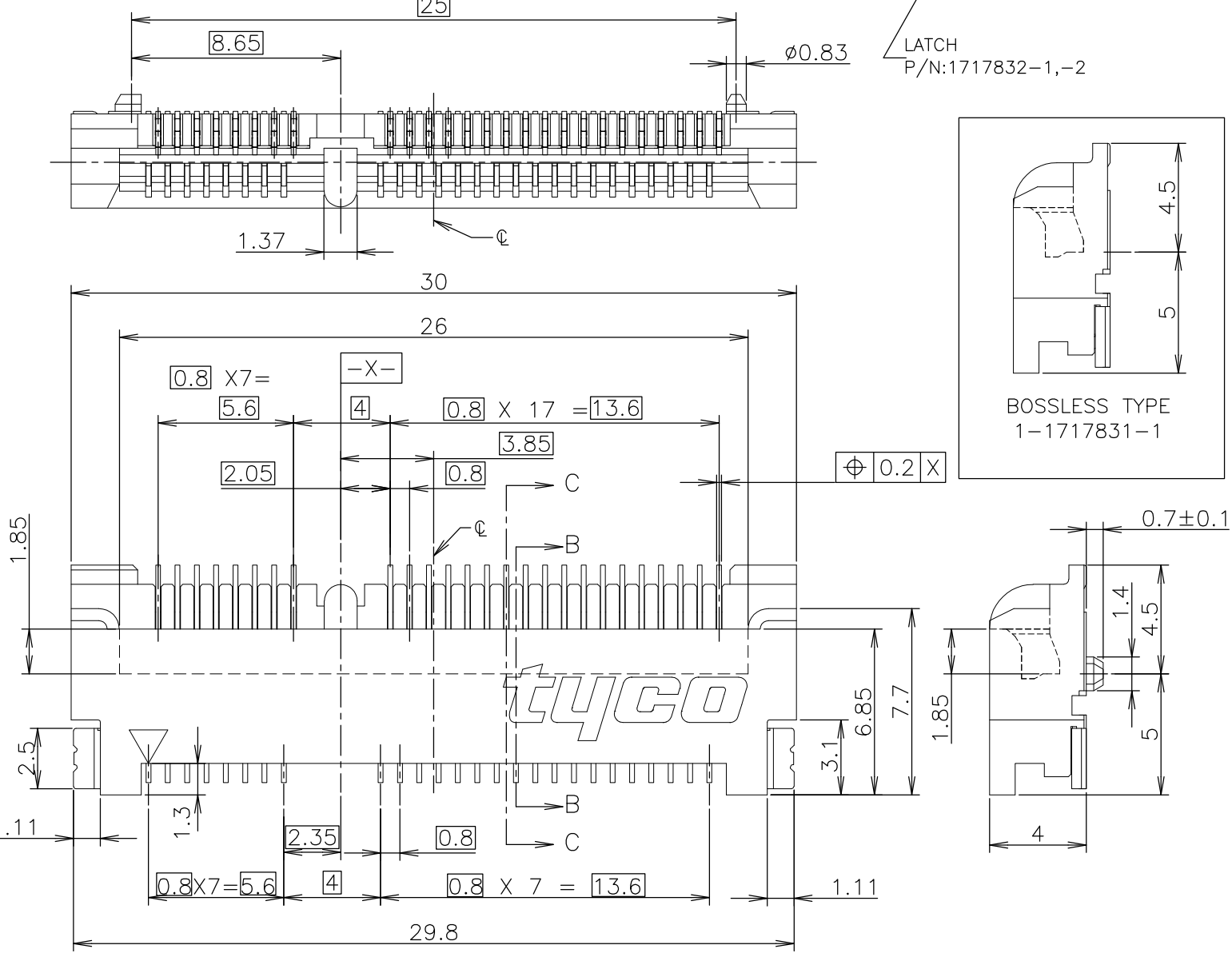

LOC	DIST	REVISIONS			
P	LTR	DESCRIPTION	DATE	DWN	APVD
J		C1	REVISED PER ECO-11-005033	26MAR11	RK HMR

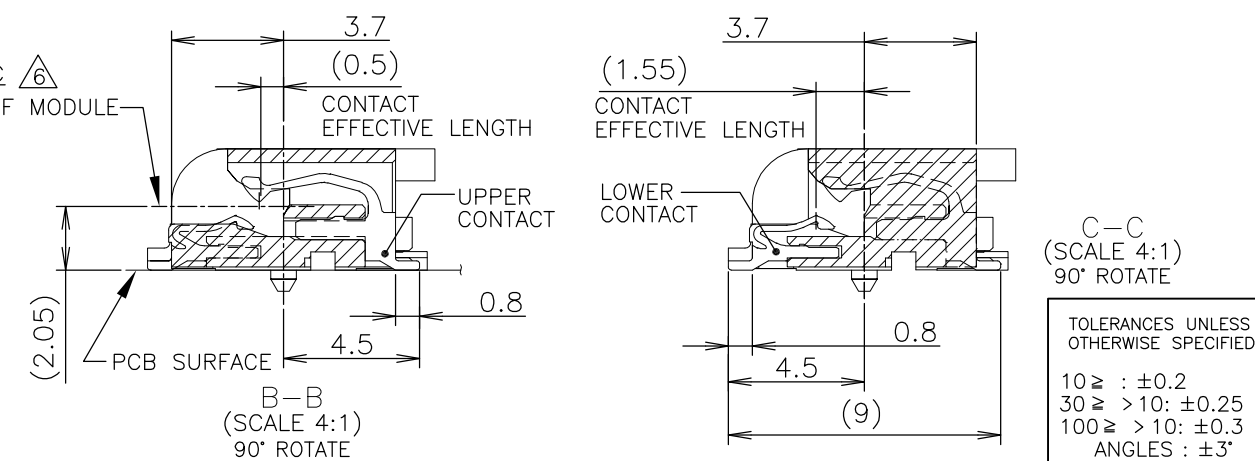
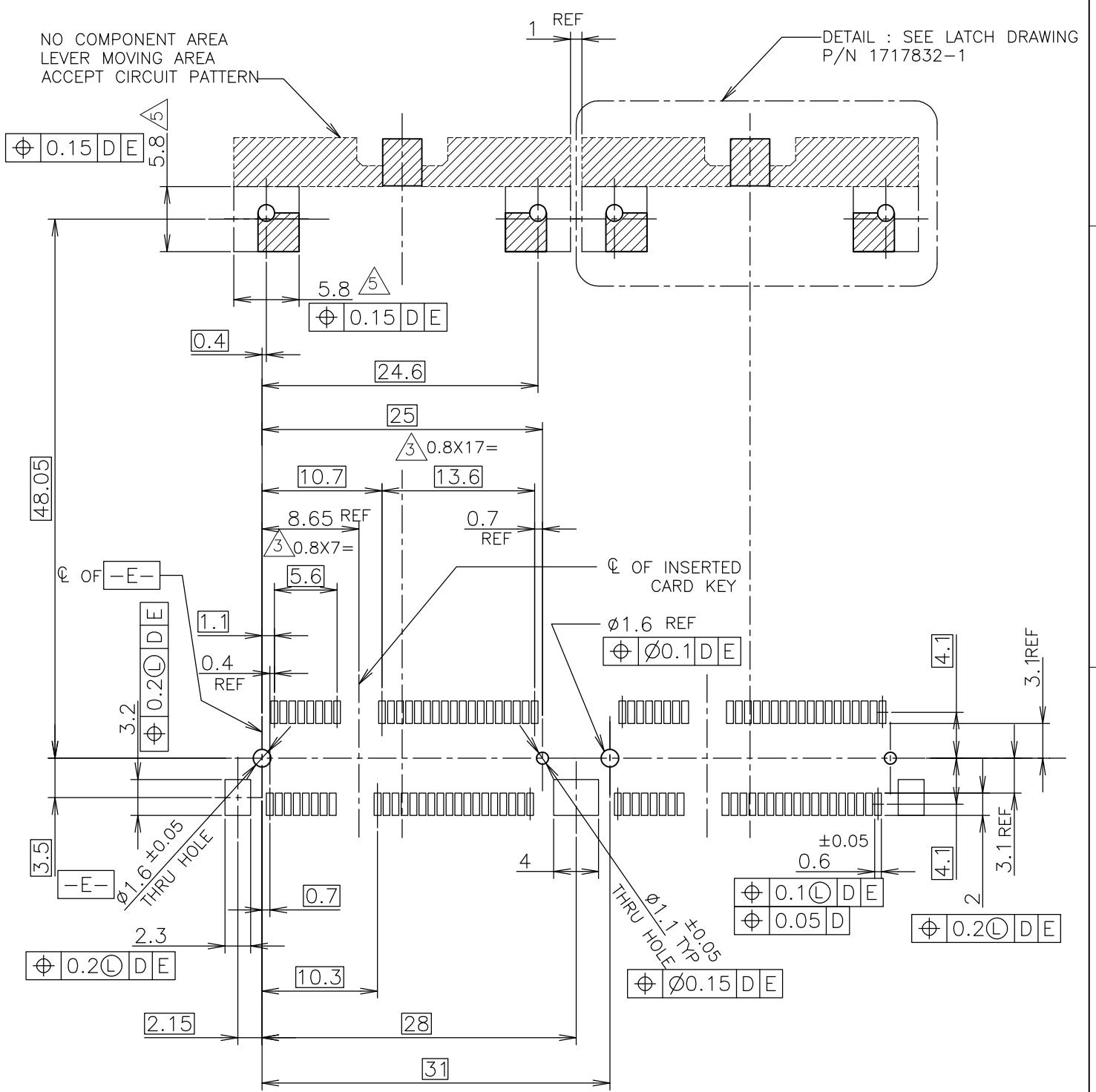

THIS DRAWING IS A CONTROLLED DOCUMENT.

DIMENSIONS: MM	TOLERANCES UNLESS OTHERWISE SPECIFIED:
0 PLC ± -	1 PLC ± -
2 PLC ± -	3 PLC ± -
4 PLC ± -	ANGLES ± -
MATERIAL SEE NOTE	FINISH SEE NOTE

DWN J.TANIGAWA 100CT03	TE Connectivity
CHK Y.YAMAMOTO 100CT03	
APVD Y.YAMAMOTO 100CT03	
NAME	
PRODUCT SPEC 108-5899	SEMI HARD TRAY & EMBOSS TAPE SUPPLY MINI PCI EXPRESS CONNECTOR ASSEMBLY
APPLICATION SPEC	SIZE CAGE CODE DRAWING NO RESTRICTED TO
WEIGHT 1.2g	A3 00779 C-1717831
CUSTOMER DRAWING	SCALE 4:1 SHEET 1 OF 4 REV C1

P	LTR	DESCRIPTION	DATE	DWN	APVD
-	-	SEE SHEET 1	-	-	-

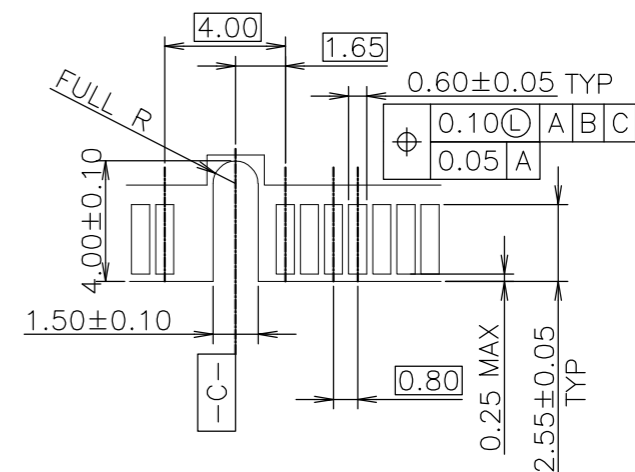
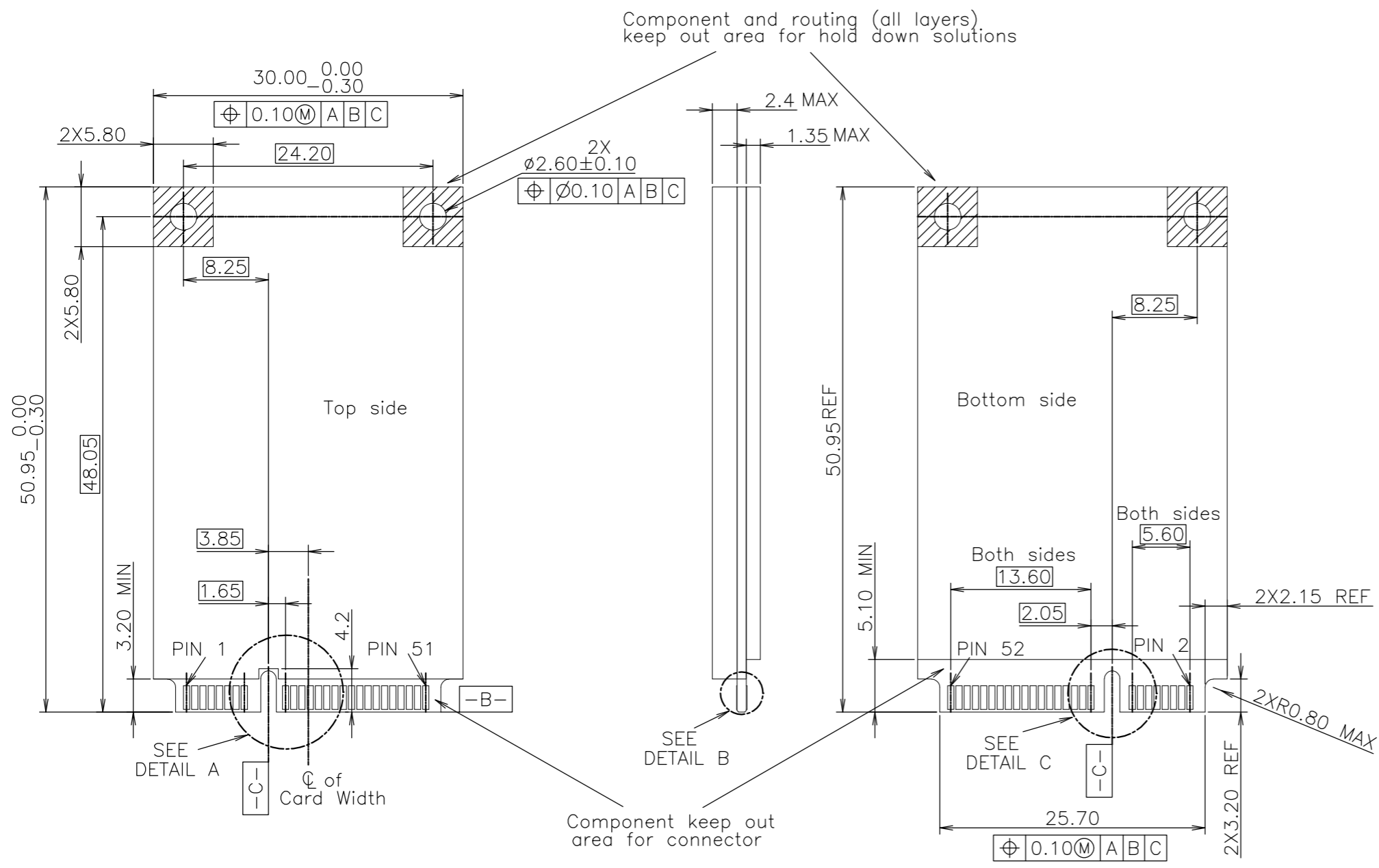

DETAIL A SCALE 4:1

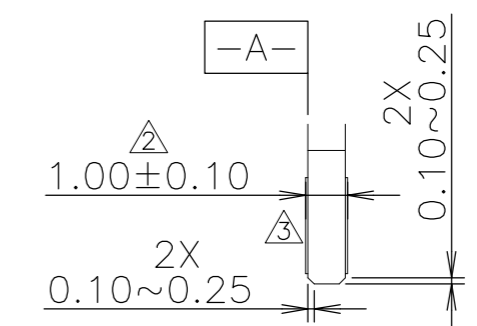

DETAIL B SCALE 4:1

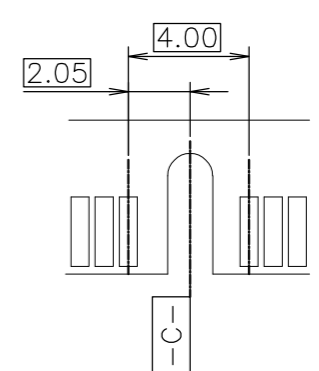

DETAIL C SCALE 4:1

- NOTES
- 1. PCI EXPRESS MINI CARD, PCB THICKNESS 1.0MM.
 - 2. CARD THICKNESS APPLIES ACROSS TABS AND INCLUDES PLATING AND/OR METALIZATION.
 - 3. BEVEL MUST BE FREE OF CUTTING BURRS.

THIS DRAWING IS A CONTROLLED DOCUMENT.		DWN	TE Connectivity													
DIMENSIONS: MM		CHK														
		APVD														
<p>TOLERANCES UNLESS OTHERWISE SPECIFIED:</p> <table border="1"> <tr><td>0 PLC</td><td>± -</td></tr> <tr><td>1 PLC</td><td>± -</td></tr> <tr><td>2 PLC</td><td>± -</td></tr> <tr><td>3 PLC</td><td>± -</td></tr> <tr><td>4 PLC</td><td>± -</td></tr> <tr><td>ANGLES</td><td>± -</td></tr> <tr><td>FINISH</td><td>± -</td></tr> </table>		0 PLC			± -	1 PLC	± -	2 PLC	± -	3 PLC	± -	4 PLC	± -	ANGLES	± -	FINISH
0 PLC	± -															
1 PLC	± -															
2 PLC	± -															
3 PLC	± -															
4 PLC	± -															
ANGLES	± -															
FINISH	± -															
MATERIAL		PRODUCT SPEC	SEMI HARD TRAY & EMBOSS TAPE SUPPLY MINI PCI EXPRESS CONNECTOR ASSEMBLY													
		APPLICATION SPEC	SIZE	RESTRICTED TO												
		WEIGHT	A3													
		CUSTOMER DRAWING	CAGE CODE													
			00779													
			DRAWING NO													
			C-1717831													
			SCALE													
			2:1													
			SHEET													
			2 OF 4													
			REV													
			C1													

THIS DRAWING IS UNPUBLISHED. RELEASED FOR PUBLICATION OCT , 2003.
 © COPYRIGHT 2003 By - ALL RIGHTS RESERVED.

LOC	DIST	REVISIONS			
P	LTR	DESCRIPTION	DATE	DWN	APVD
J	/	-	SEE SHEET 1	-	-

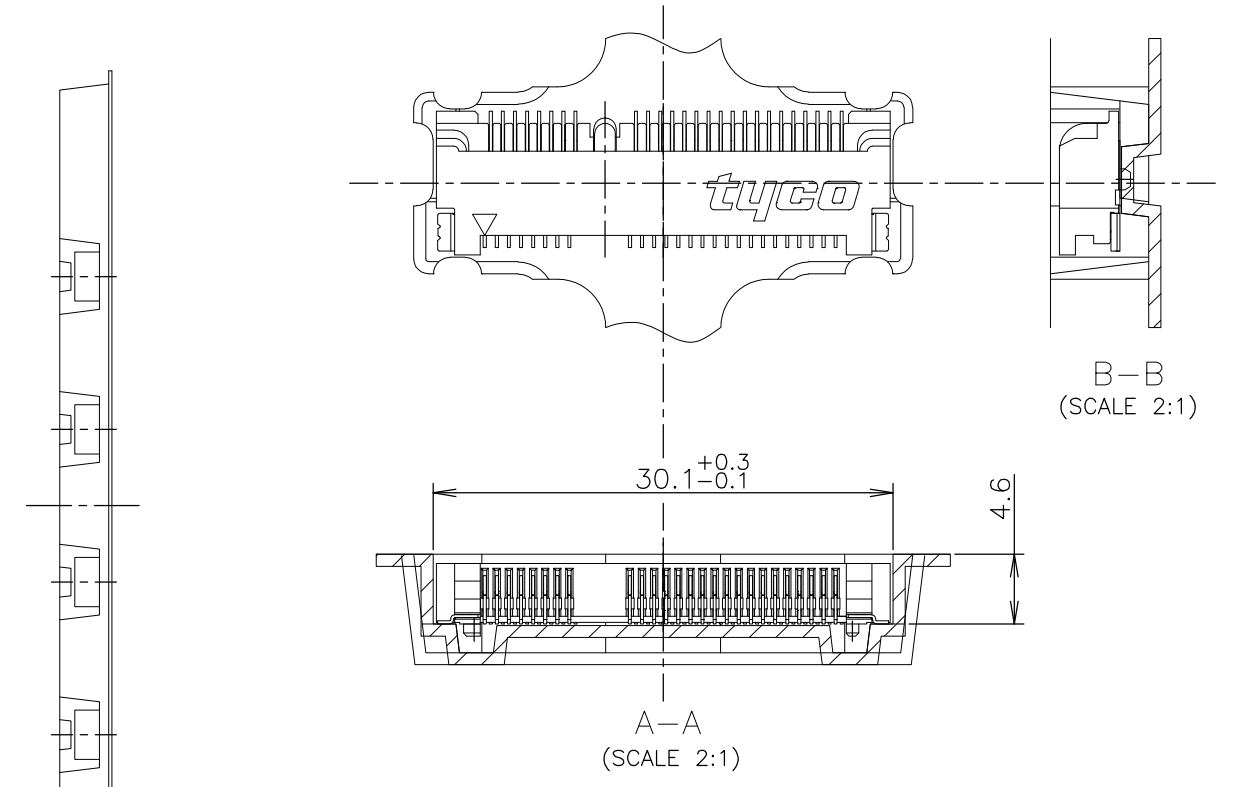
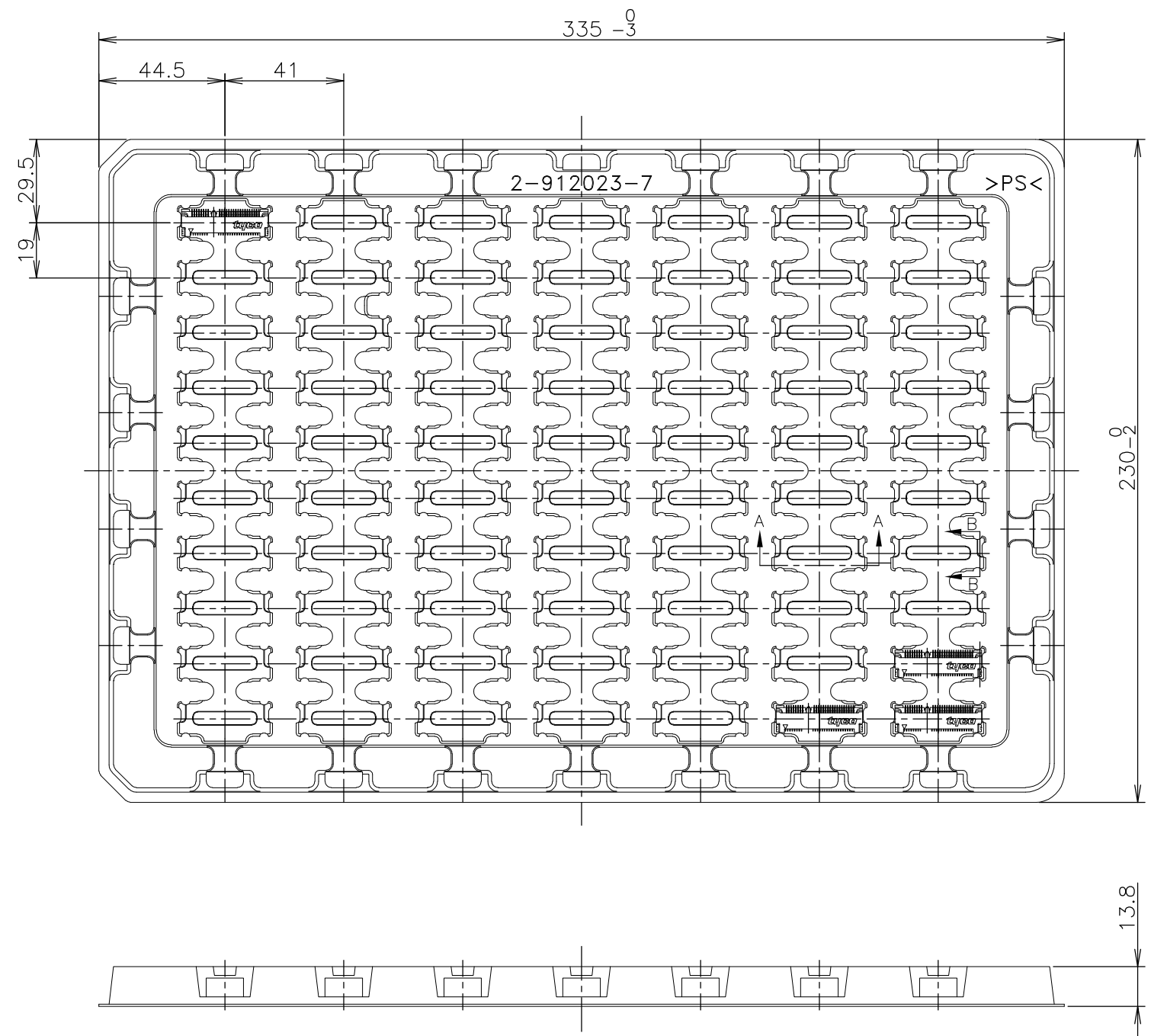

NOTE
 1. THE DIRECTION OF EACH CONNECTOR ON A TRAY IS REFERRED TO THIS DWG.

BOSSLESS	70EA/TRAY	2-912023-7	1-1717831-1
//	70EA/TRAY	2-912023-7	1717831-1
REMARK	QTY	TRAY P/N	P/N

THIS DRAWING IS A CONTROLLED DOCUMENT.		DWN	TE Connectivity NAME SEMI HARD TRAY & EMBOSS TAPE SUPPLY MINI PCI EXPRESS CONNECTOR ASSEMBLY				
DIMENSIONS: MM		CHK				PRODUCT SPEC	108-5899
TOLERANCES UNLESS OTHERWISE SPECIFIED:		APVD				APPLICATION SPEC	
0 PLC ± - 1 PLC ± - 2 PLC ± - 3 PLC ± - 4 PLC ± - ANGLES ± - FINISH ± -		WEIGHT				SIZE	A3
TOLERANCES UNLESS OTHERWISE SPECIFIED ±0.5		MATERIAL	CAGE CODE	00779			
			DRAWING NO	C-1717831			
			RESTRICTED TO				
CUSTOMER DRAWING			SCALE	NTS			
			SHEET	3 OF 4			
			REV	C1			

4

3

2

1

THIS DRAWING IS UNPUBLISHED. RELEASED FOR PUBLICATION OCT , 2003.
 © COPYRIGHT 2003 By - ALL RIGHTS RESERVED.

LOC	DIST	REVISIONS			
P	LTR	DESCRIPTION	DATE	DWN	APVD
J	/	SEE SHEET 1	-	-	-

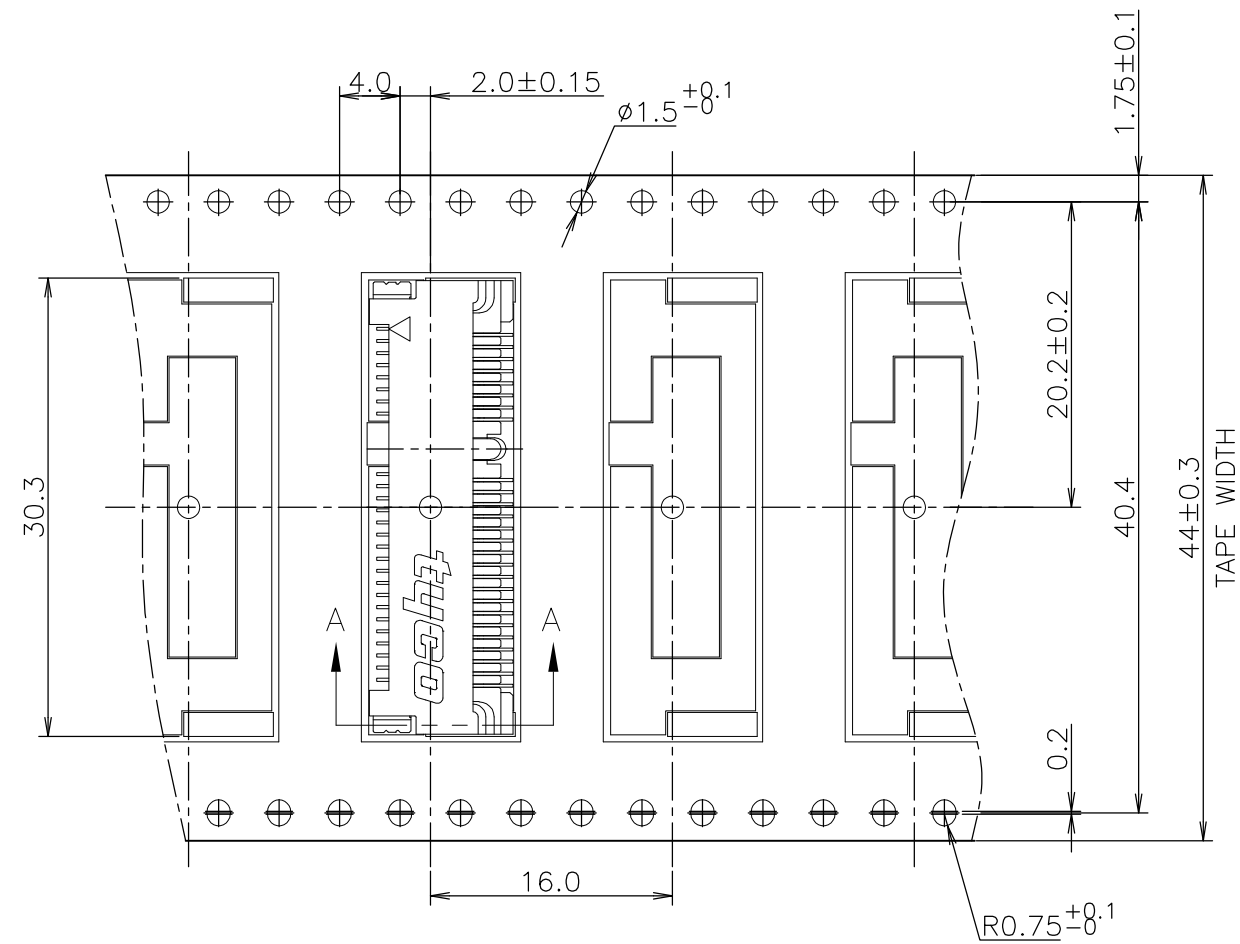

1 PEELING RESISTANCE : 0.1N~1.3N
 (10gf~130gf)
 SPEED : 300mm/min

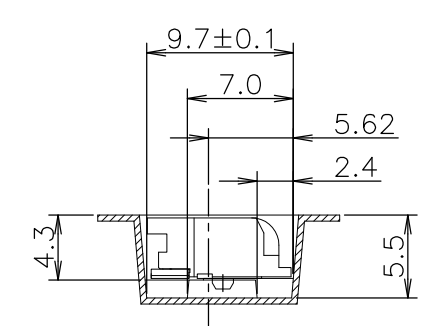

A-A

TOP OF REEL →

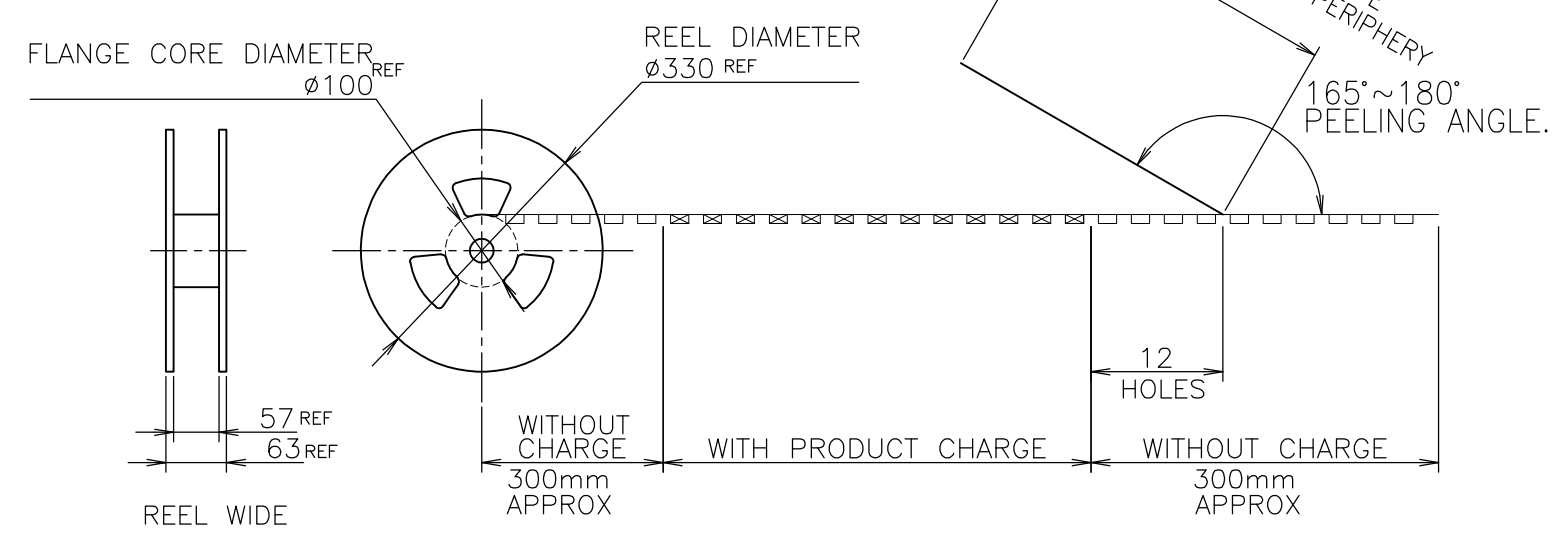

//	500EA	5-912103-9	1717831-2
REMARK	QTY/REEL	EMBOSS TAPE P/N	P/N

THIS DRAWING IS A CONTROLLED DOCUMENT.		DWN	TE Connectivity NAME SEMI HARD TRAY & EMBOSS TAPE SUPPLY MINI PCI EXPRESS CONNECTOR ASSEMBLY				
DIMENSIONS:	TOLERANCES UNLESS OTHERWISE SPECIFIED:	CHK				PRODUCT SPEC	
MM	0 PLC ± -	APVD				108-5899	
	1 PLC ± -	PRODUCT SPEC				APPLICATION SPEC	
	2 PLC ± -	WEIGHT	SIZE	CAGE CODE	DRAWING NO		
	3 PLC ± -		A3	00779	C-1717831		
	4 PLC ± -		CUSTOMER DRAWING				
MATERIAL	FINISH		SCALE	SHEET	REV		
			2:1	4 OF 4	C1		