

| LOC | DIST | REVISIONS | | | |
|-----|------|-------------|-----------------------------|-----------|--------|
| P | LTR | DESCRIPTION | DATE | DWN | APVD |
| AJ | 16 | A | REVISED PER EC 0514-0150-05 | 05OCT2005 | REH JL |

- △ CARBON STEEL
- △ BRASS PER ASTM-B-16
- △ PHOSPHOR BRONZE PER ASTM-B-139
- △ POLYMETHYLPENTENE: GENERAL PURPOSE
- △ SILICONE RUBBER PER ZZ-R-765
- △ ZINC DIE CAST PER ASTM-B-86
- △ GOLD PLATE PER ASTM-B-488, 0.38μm [.000015] MIN THICKNESS
- △ NICKEL PLATE PER QQ-N-290, 1.27μm [.000050] MIN THICKNESS
- △ NICKEL PLATE PER QQ-N-290, 2.54μm [.000100] MIN THICKNESS

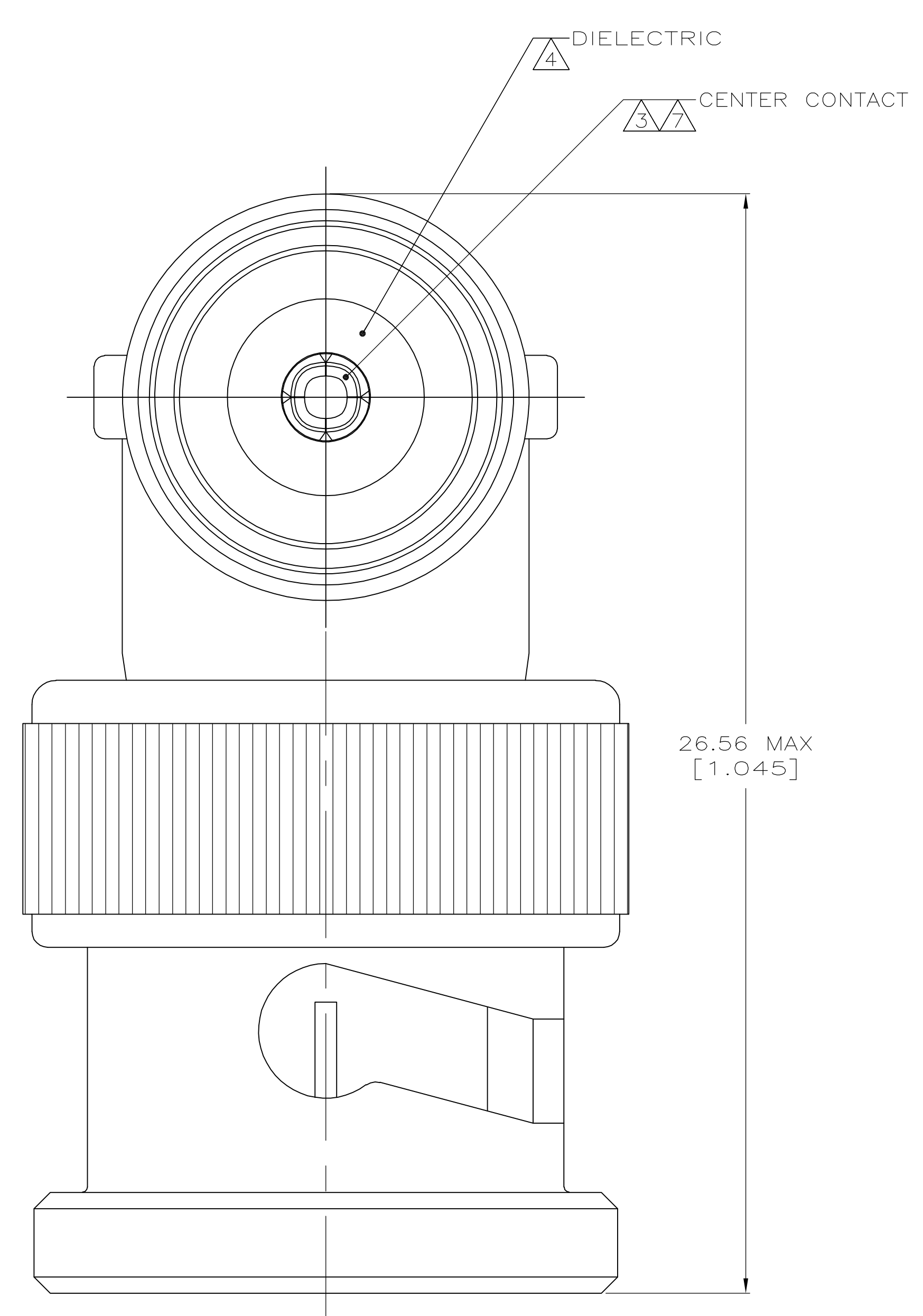
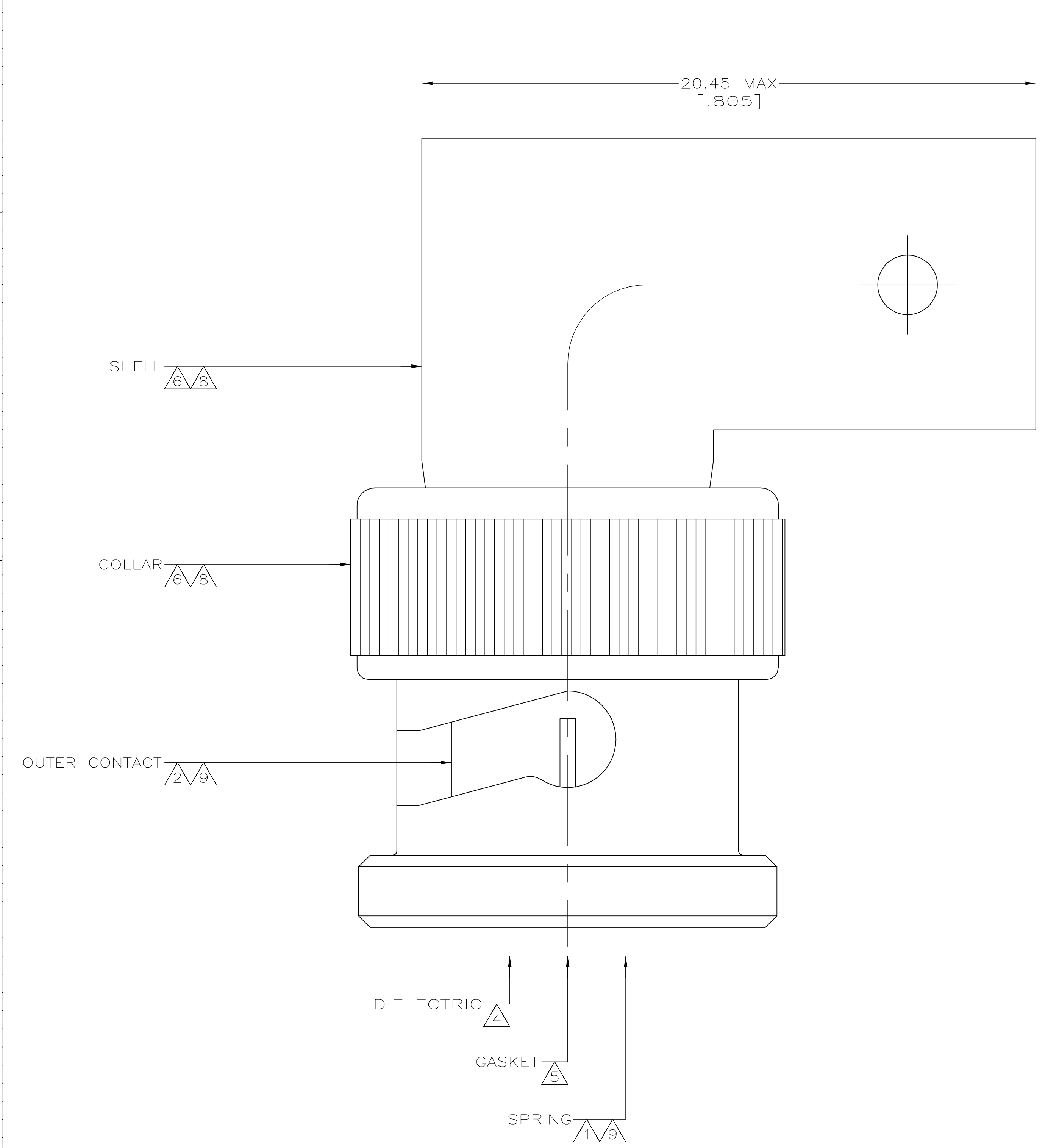

5414666-1
 PART NUMBER

| | | | | |
|--|--|-------------------------------|---|--|
| THIS DRAWING IS A CONTROLLED DOCUMENT. | | DWN L. VARELA - 18APR2005 | Tyco Electronics Corporation Harrisburg, PA 17105-3608 | |
| DIMENSIONS: mm [INCHES] | | CHK J. HAVENER 18APR2005 | NAME J. LIPPERT 18APR2005 | |
| TOLERANCES UNLESS OTHERWISE SPECIFIED: | | PRODUCT SPEC | | |
| 0. PLC ± - | | APPLICATION SPEC | | |
| 1. PLC ± - | | SIZE CAGE CODE DRAWING NO | | |
| 2. PLC ± - | | A1 00779 C=5414666 | | |
| 3. PLC ± - | | RESTRICTED TO | | |
| 4. PLC ± - | | CUSTOMER DRAWING | | |
| ANGLES ± - | | SCALE 10:1 SHEET 1 OF 1 REV A | | |
| FINISH SEE NOTES | | | | |