

DO NOT SCALE FROM THIS PRINT

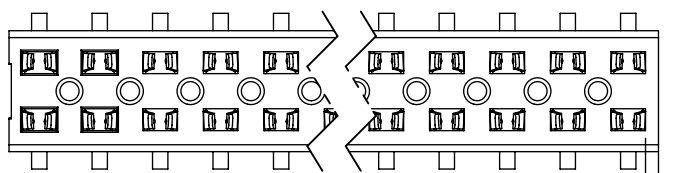

FIG 6  
-BE OPTION  
(SAME AS FIG 1 EXCEPT INSULATOR)

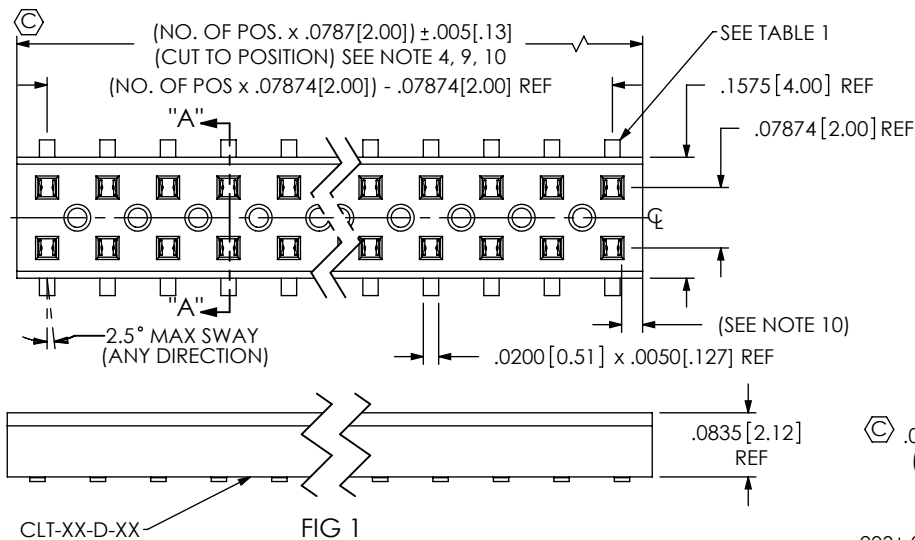

FIG 1

TABLE 1	
OPTION	USE CONTACT
CLT-150-02-L(M)-D-XX	C-114-22-L(M)
CLT-150-02-F(M)-D-XX	C-114-22-F(M)
CLT-150-02-G-D-XX	C-114-22-G
CLT-150-02-L(M)-D-BE-XX	C-114-22-L(M)
CLT-150-02-F(M)-D-BE-XX	C-114-22-F(M)
CLT-150-02-G-D-BE-XX	C-114-22-G
CLT-150-02-S(M)-D-BE-XX	C-114-22-S(M)
CLT-150-02-H-D-BE-XX	C-114-22-H
CLT-150-02-H-D-XX	C-114-22-H

SEE NOTE 11

PATENT NUMBERS  
5713755  
5961339

- NOTES:
- ⊕ REPRESENTS A CRITICAL DIMENSION.
  - COPLANARITY TO BE .004 FOR POSITIONS 2-25, .006 FOR POSITIONS 26-34, AND .008 FOR 35-50.
  - MINIMUM PUSHOUT FORCE: .5 LB.
  - WILL LOSE A POSITION FOR EVERY CUT MADE ON A SOCKET STRIP.
  - ALL OPTIONS: PACKAGE POSITIONS -04 THRU -50 IN PT-CLX002-D TUBE AS SHOWN IN VIEWS, WITH TWO TP-12 PLUGS PER TUBE. LAYER PACKAGE POSITIONS -02 & -03.
  - SHEAR TAILS TO DIMENSION SHOWN.
  - PARTS TO BE SYMMETRICAL ABOUT  $\bar{C}$
  - .005 MAX. BURR.
  - CUT FLASH TO BE .010 [.25] MAX WITH NO FLASH ALLOWED IN HOLES OR EXTENDING BELOW LEADS
  - STANDARD BODY ENDWALL AFTER CUTTING: .0215 MIN.
  - BE BODY ENDWALL AFTER CUTTING: .0169 ± .003 [.429 ± .08]
  - C-114-02 CAN BE USED FOR C-114-22. C-114-22-XX IS FOR AUTOMATED ASSEMBLY PROCESSES ONLY.

CLT-1XX-02-XX-D-XX

No OF POS. PER ROW  
-02 THRU -50

LEAD STYLE  
-02: SURFACE MOUNT  
(SEE TABLE 1)

PLATING SPECIFICATION

- F: 3μ" SELECTIVE GOLD IN CONTACT AREA, MATTE TIN ON TAIL
- L: 10μ" SELECTIVE GOLD IN CONTACT AREA, MATTE TIN ON TAIL
- G: 10μ" GOLD IN CONTACT AREA, 3μ" GOLD ON TAIL
- S: 30μ" SELECTIVE GOLD IN CONTACT AREA, MATTE TIN ON TAIL
- H: 30μ" GOLD IN CONTACT AREA, 3μ" GOLD ON TAIL
- FM: 3μ" SELECTIVE GOLD IN CONTACT AREA, MATTE TIN ON TAIL
- LM: 10μ" SELECTIVE GOLD IN CONTACT AREA, MATTE TIN ON TAIL
- SM: 30μ" SELECTIVE GOLD IN CONTACT AREA, MATTE TIN ON TAIL

OPTION

- P: PICK & PLACE PAD AVAILABLE ON POSITIONS 04 THRU 50 ONLY (SEE FIG. 2, SHT 2. USE LMP-03)
- TR: TAPE AND REEL PACKAGING (02 THRU 36 POS ONLY)
- BE: BOTTOM ENTRY (SEE FIG. 6, USE CLT-XX-D-BE-XX)
- A: ALIGNMENT PIN (MOLDED OR STAKED) (SEE FIGS. 3 & 4, SHT 2) (STAKED MIN 5 POS) (MOLDED MIN 3 POS)
- K: POLYIMIDE FILM PAD (AVAILABLE ON POS. 4 THRU 50 ONLY) (.005 [.13] THICKNESS WITH SILICONE ADHESIVE) (SEE FIG 5, SHT 2) (USE K-500-300)

ROW SPEC.  
-D DOUBLE ROW  
(USE CLT-XX-D EXCEPT FOR -BE OPTION)

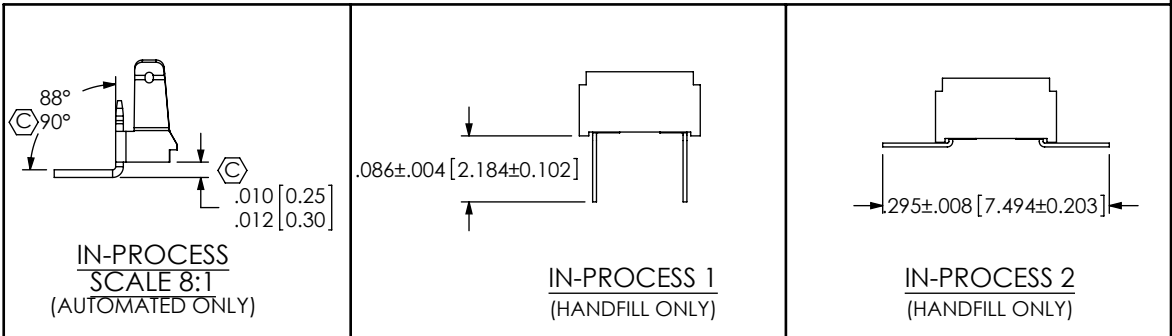
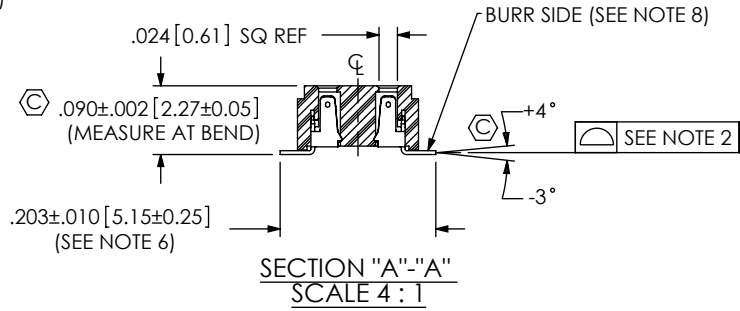

UNLESS OTHERWISE SPECIFIED, DIMENSIONS ARE IN INCHES.

TOLERANCES ARE:

DECIMALS	ANGLES
.XX: ±.01 [.3]	2°
.XXX: ±.005 [.13]	
.XXXX: ±.0020 [.051]	

PROPRIETARY NOTE

THIS DOCUMENT CONTAINS INFORMATION CONFIDENTIAL AND PROPRIETARY TO SAMTEC, INC. AND SHALL NOT BE REPRODUCED OR TRANSFERRED TO OTHER DOCUMENTS OR DISCLOSED TO OTHERS OR USED FOR ANY PURPOSE OTHER THAN THAT WHICH IT WAS OBTAINED WITHOUT THE EXPRESSED WRITTEN CONSENT OF SAMTEC, INC.



520 PARK EAST BLVD. NEW ALBANY, IN 47150  
PHONE: 812-944-6733 FAX: 812-948-5047  
e-Mail info@SAMTEC.com code 55322

MATERIAL: DO NOT SCALE DRAWING SHEET SCALE: 2:1

INSULATOR: LCP, UL 94 VO, COLOR BLACK

CONTACT: PHOS BRONZE

F:\DWG\MISC\MKTG\CLT-1XX-02-XX-D-XX-MKT.SLDDRW

DESCRIPTION: 2MM LOW PROFILE SOCKET STRIP

DWG. NO. CLT-1XX-02-XX-D-XX

BY: BRATCHER 10/03/1994 SHEET 1 OF 2

FIG 2  
-P: PICK & PLACE PAD  
(4 POS MIN)

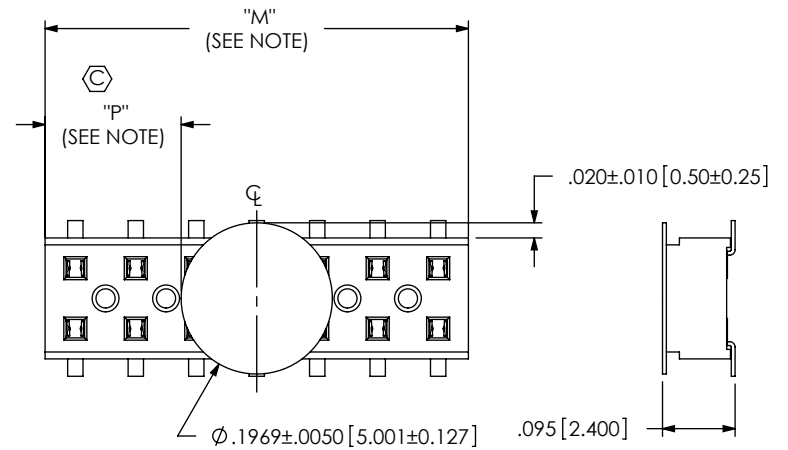
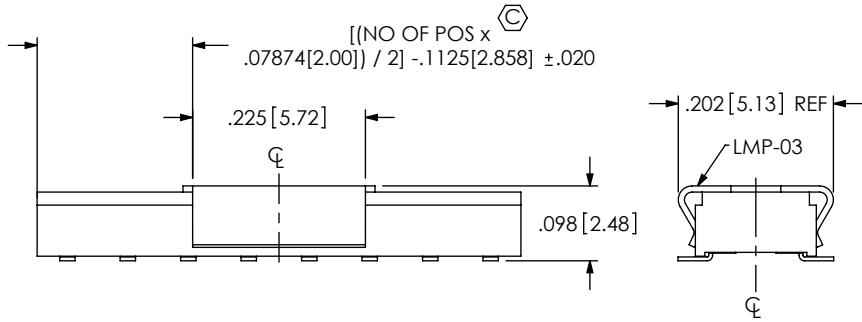

NOTE: "M" = USED MEASURED DIMENSION (REF)  
"P" = (( "M" - .1969 [5.00]) / 2 ) ± .020 [.51]

FIG 5  
-K OPTION  
(4 POS MIN)

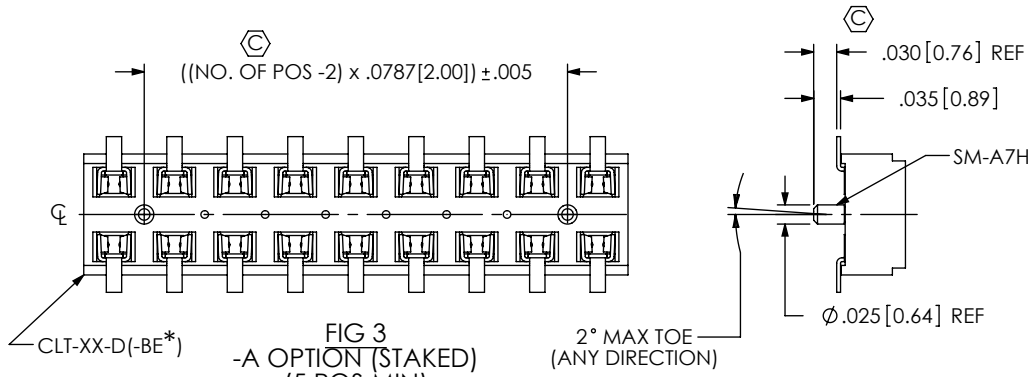
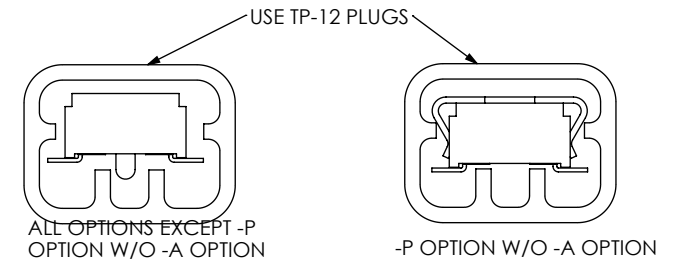

FIG 3  
-A OPTION (STAKED)  
(5 POS MIN)

\* = FOR -BE OPTION ONLY



PACKAGING VIEWS  
(SEE NOTE 5)  
PT-CLX002-D

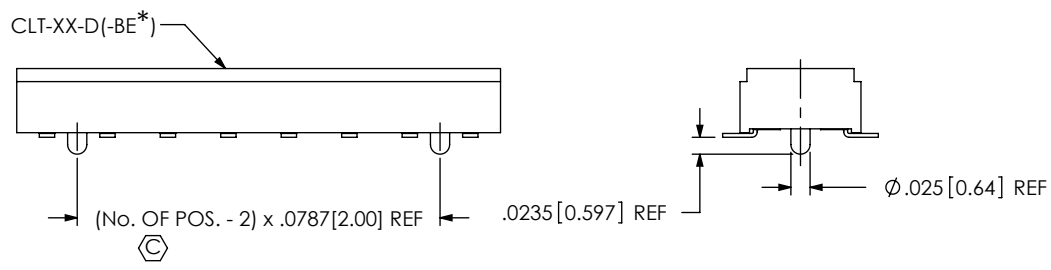

FIG 4  
-A OPTION (MOLDED)  
(3 POS MIN)

\* = FOR -BE OPTION ONLY

PROPRIETARY NOTE  
THIS DOCUMENT CONTAINS INFORMATION  
CONFIDENTIAL AND PROPRIETARY TO  
SAMTEC, INC. AND SHALL NOT BE REPRODUCED  
OR TRANSFERRED TO OTHER DOCUMENTS OR  
DISCLOSED TO OTHERS OR USED FOR ANY  
PURPOSE OTHER THAN THAT WHICH IT WAS  
OBTAINED WITHOUT THE EXPRESSED WRITTEN  
CONSENT OF SAMTEC, INC.



520 PARK EAST BLVD, NEW ALBANY, IN 47150  
PHONE: 812-944-6733 FAX: 812-948-5047  
e-Mail info@SAMTEC.com code 55322

DO NOT SCALE DRAWING

SHEET SCALE: 4:1

DESCRIPTION:  
2MM LOW PROFILE SOCKET STRIP

DWG. NO.  
CLT-1XX-02-XX-D-XX

BY: BRATCHER 10/03/1994 SHEET 2 OF 2